

TT

590

S88

GRADING BY HEIGHTS
AND WIDTHS

CHAS. J. STONE



Class TT590

Book S83

Copyright N^o _____

COPYRIGHT DEPOSIT.





*Yours Truly
Chas. J. Stone*

STONE'S

SCIENTIFIC SYSTEM

OF GRADING

Patterns For Men's Garments

By the Proportions of Heights and Widths
of the Human Form

BY
CHAS. J. STONE
CHICAGO, ILL.

PUBLISHED BY
THE CHAS. J. STONE CO.
CHICAGO

T. J. Stone

COPYRIGHTED 1912 BY
THE CHAS. J. STONE CO.

17-115

\$10.00
© Cl. A312512
no 1

orig. Apr. 26, 1912.

INTRODUCTORY

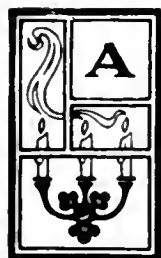

ALL experienced garment designers and pattern cutters know from actual practice that while a garment drafted 38 breast for a 38 size man will fit properly, a 33 breast coat for a 33 breast man will be too small, and a 43 breast coat for a man measuring 43 breast will be too large, and in actual practice the cutter knows that the small sizes will come out small and the larger sizes, large. Besides these difficulties in sizing garments the cutters have also discovered that it is impossible to draft two patterns alike, but by a scientific method of grading it is possible to produce any number of patterns with the correct increase and decrease in all sizes and with the same shape and outlines as in the original model pattern that we grade from.

First of all let me impress upon the student's mind, that grading can not be done by angling out from any imaginary point (simply starting somewhere, may land you nowhere). The grading of patterns means an equal increase and decrease in size, but remember that while the breast, waist and seat increases, one inch for each size, the height does not increase in the same proportions as the breast, hence the angled out lines do not give the proper increase and decrease desired.

Second, do not attempt to grade from youth's to men's nor from slims to stouts, for they are all of different types, forms and heights, and so classed by experienced cutters and designers.

CLASSIFICATIONS.

First comes the regulars, that is, patterns for the regular normal man. The first model pattern is cut for a man measuring in height 5 feet 8 inches, breast 38, waist 34, seat 39, with vest and trousers to correspond.

Second comes the tall and slims, height 6 feet, breast 36, waist 32, seat 37.

Third is the stouts, fats, and the corpulent.

Stouts—Breast 40, waist 38, seat 41.

Fats—Breast 42, waist 42, seat 43.

Corpulents—Breast 44, waist 46, seat 46.

All 5 feet 8 inches in height.

Fourth, we have the stubs.

The stout stubs.

The fat stubs.

The corpulent stubs.

All 5 feet 6 inches in height.

Fifth, we have the youths.

Height 5 feet 7 inches.

Breast 36, waist 31, seat 38.

NOTE.—To grade down to 30 breast space down four sizes and divide into five parts.

TROUSERS.

For regular trousers use pattern 34 waist, 39 seat, with knee and bottom size to prevailing style.

For stout men's use pattern 38 waist, 40 seat.

For fat men's use pattern 42 waist, 43 seat.

For corpulent men's use pattern 46 waist, 46 seat.

Increase and decrease waist 1 inch and increase and decrease seat $\frac{3}{4}$ inch for each size.

In grading patterns, first cut a model for each type of form, then proceed to make the different grades.

As previously stated, the small sizes get too small and the large sizes get too large, so in grading, space for four sizes and divide the spaces into five parts, thereby decreasing the large sizes and increasing the smaller sizes.

In the normal patterns start with size 38, go up four sizes from 38 to 42, divide this into five parts and 42 will become size 43, then go down four sizes from 38 to 34, divide this into five parts and 34 will be size 33.

Sack overcoats are graded on same lines as the regular sack coat.

NOTE.—In laying out the grade, use an ordinary square and use the divisions 19—21 all over; 19 is for 38 and 21 is for 42, which is 4 sizes. This is divided into 5 parts as will be further explained with the grades.

NOTE.—Tools to be used: Proportional divider, parallel rulers and perforating needle, besides the ordinary tailor's square.

DIAGRAMS A AND B

(PRELIMINARY)

Diagram A—The Backpart—Draw a straight line on grading paper as per line A, U, S and I. The heavy line A, B, T, C, D, E, F and G is the 38 size pattern. Lay the pattern so that the bottom part C is $\frac{3}{4}$ inch in from straight line I and in this position copy off the back. Square a line across from B through point F, then square breast line U-V. Top of sidebody, line E-O is parallel with line B-F. Square up line from G and square out line D-Q at bottom. The first pattern being size 38, find 19 on divisions, the next pattern is 42 or 21 on divisions, so the space is 19 to 21 on divisions on the square. A to J is on 3rds.
G to K is on 3rds and K to L on 8ths.
Draw line through G and L.
F to M is on 3rds and M to N on 3rds.
Draw line through F and N.
N to I is $\frac{1}{8}$ inch.
E to O is on 3rds and O to P on 12ths.
Draw line through E and P and a parallel line from 8 for point 9.
H is the sleeve notch. Square out to 2.
2 to 3 is on 6ths. Draw a line through H and 3.
5 to 6 is on 3rds and 6 to 7 on 6ths.
D to Q is on 3rds. Set spacer on 5 and divide all over.

THE FOREPART.

The solid heavy lines represent the forepart size 38. Square breast line by front line A, B, C.

Square up front shoulder point I by breast line E.
H is $1\frac{1}{2}$ inch from G and F.
Draw line from H through L for M.
L to M is on 3rds.
I to J is on 3rds and J to K on 8ths.
Draw line through I and K.
Draw line from I to N and a parallel line from K for point O.
K to O is $\frac{1}{4}$ inch more than I to N.
Draw line through N and O and draw a parallel line through I for 2.
Parallel O and 2 by N and I.
U is end of roll of lapel and point 3 is break of roll at neck gorge.
Parallel 3-4 by I-K.
U to V is on 5ths or $\frac{7}{8}$ inch.
V to Y is on 6ths.
Draw line through U-Y.
W to X is on 5ths or $\frac{7}{8}$ inch.
Line P-S is parallel with breast line.
P to S is on 4ths and S to T on 12ths.
Draw line through P-T and parallel from 8 for 9.
5 to 6 is on 4ths and 6 to 7 on 6ths.
Q to R is on 4ths.
Set spacer on 5 and divide all the marked off grades into 5 parts. The 42 pattern will be size 43, which is correct.
The V under the arm is moved backwards and forwards on 8ths.
The pockets are lengthened and shortened on 8ths.

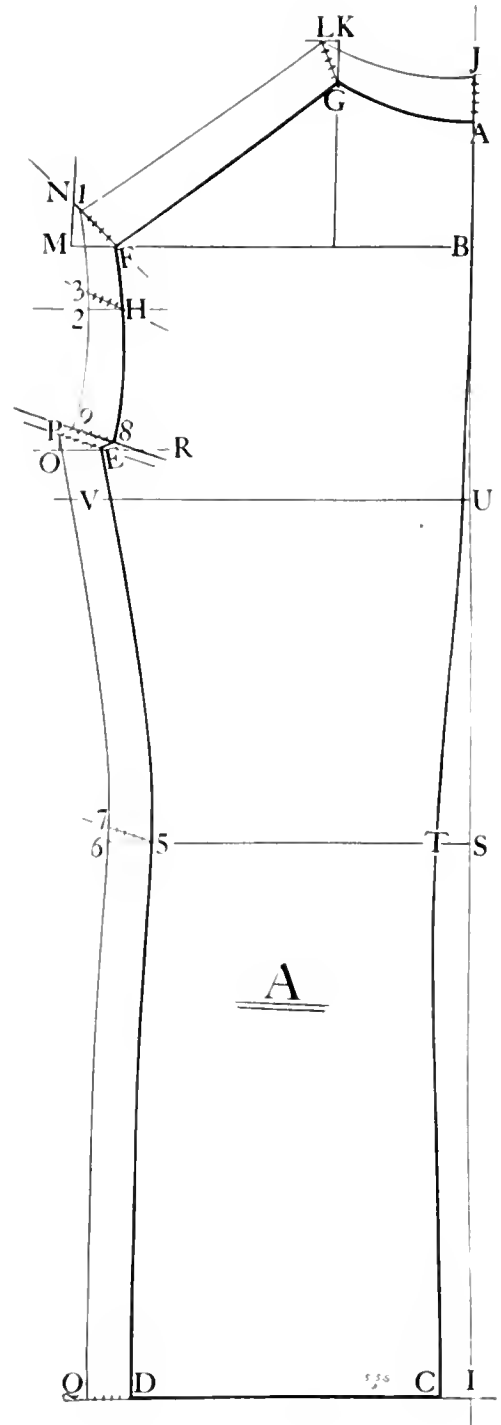
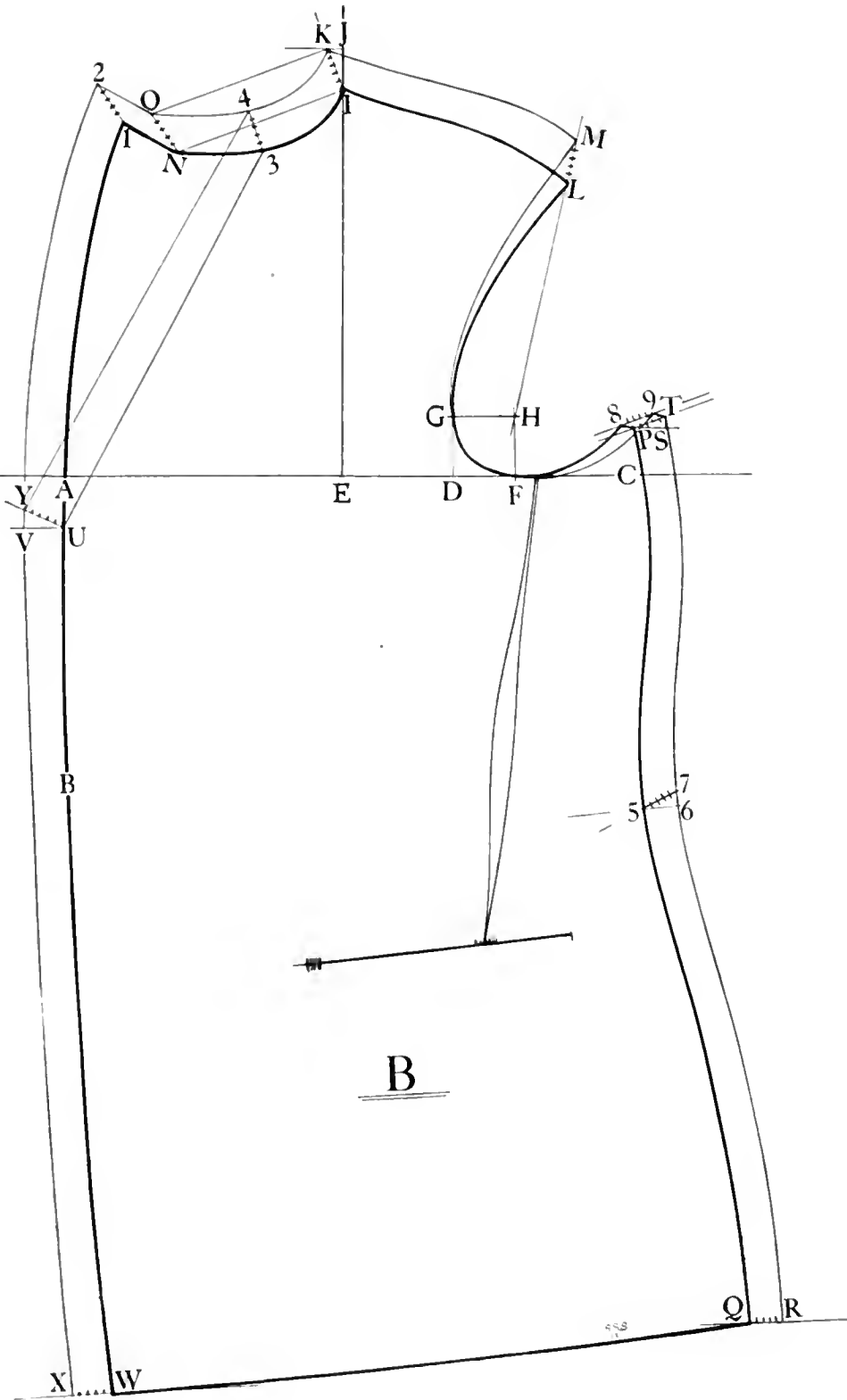

DIAGRAM C-D

Diagram C—The Backpart—The heavy line represents a 38 size back, and the grade is laid out the same as in Diagram A. Space up and out 4 sizes and divide all these spaces into 5 parts, then space off up and down on all the various lines from 38 up to 43 and 46 and down to 34, thus giving us the complete grade from 34 to 46.

The forepart D is graded the same as forepart B, using a 38 pattern. Space out 4 sizes from 38 to 42. Divide this into 5 parts, making 42 to size 43. Space up and down on all the various lines up to 46 and down to 34. The V under the arm is not graded. The pockets are graded on 8ths or as small a space as you can make. No further explanation is needed on this grade, as it is made precisely the same as Diagram A-B, only it has been increased and decreased to the smaller and the large sizes.

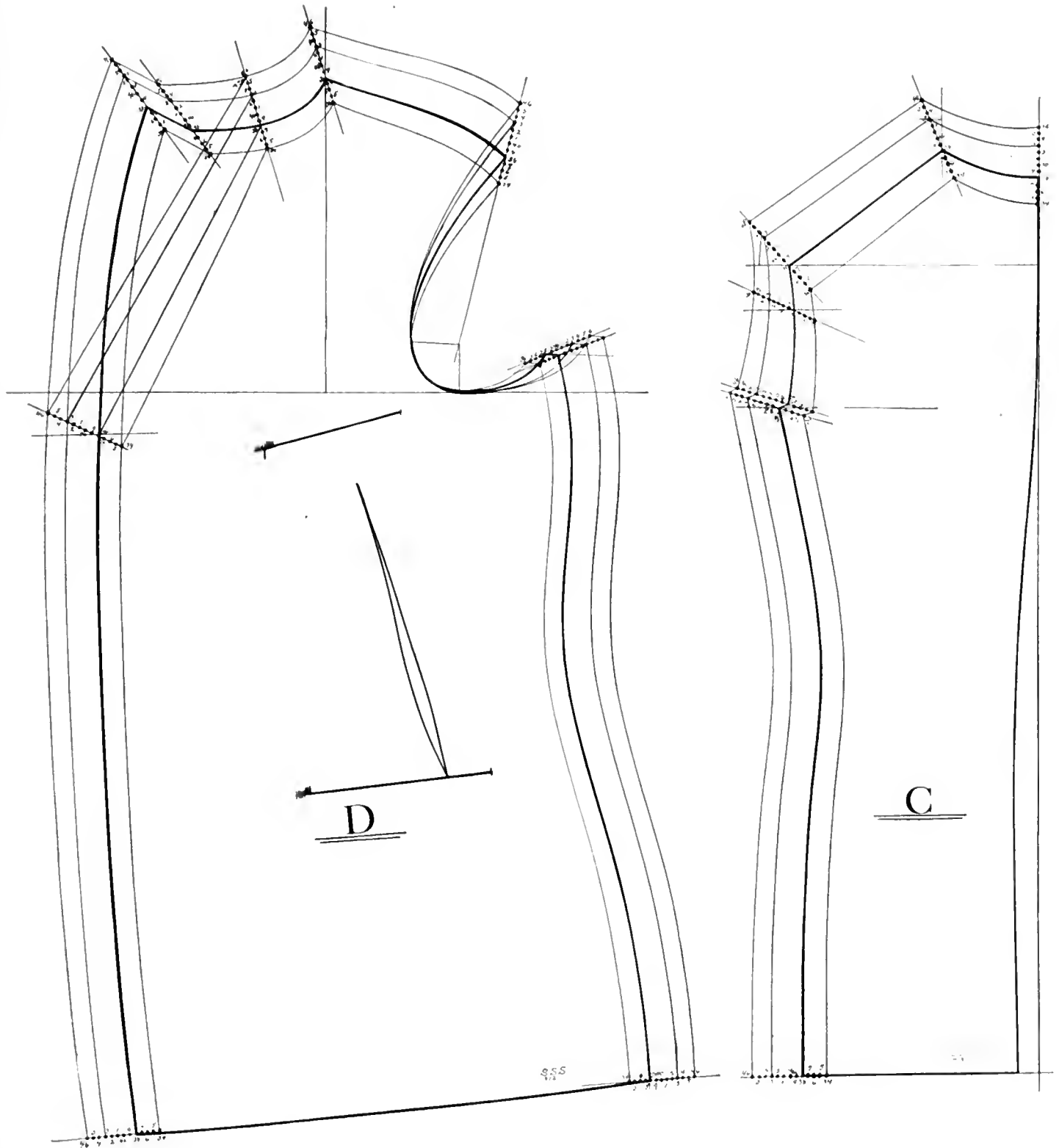
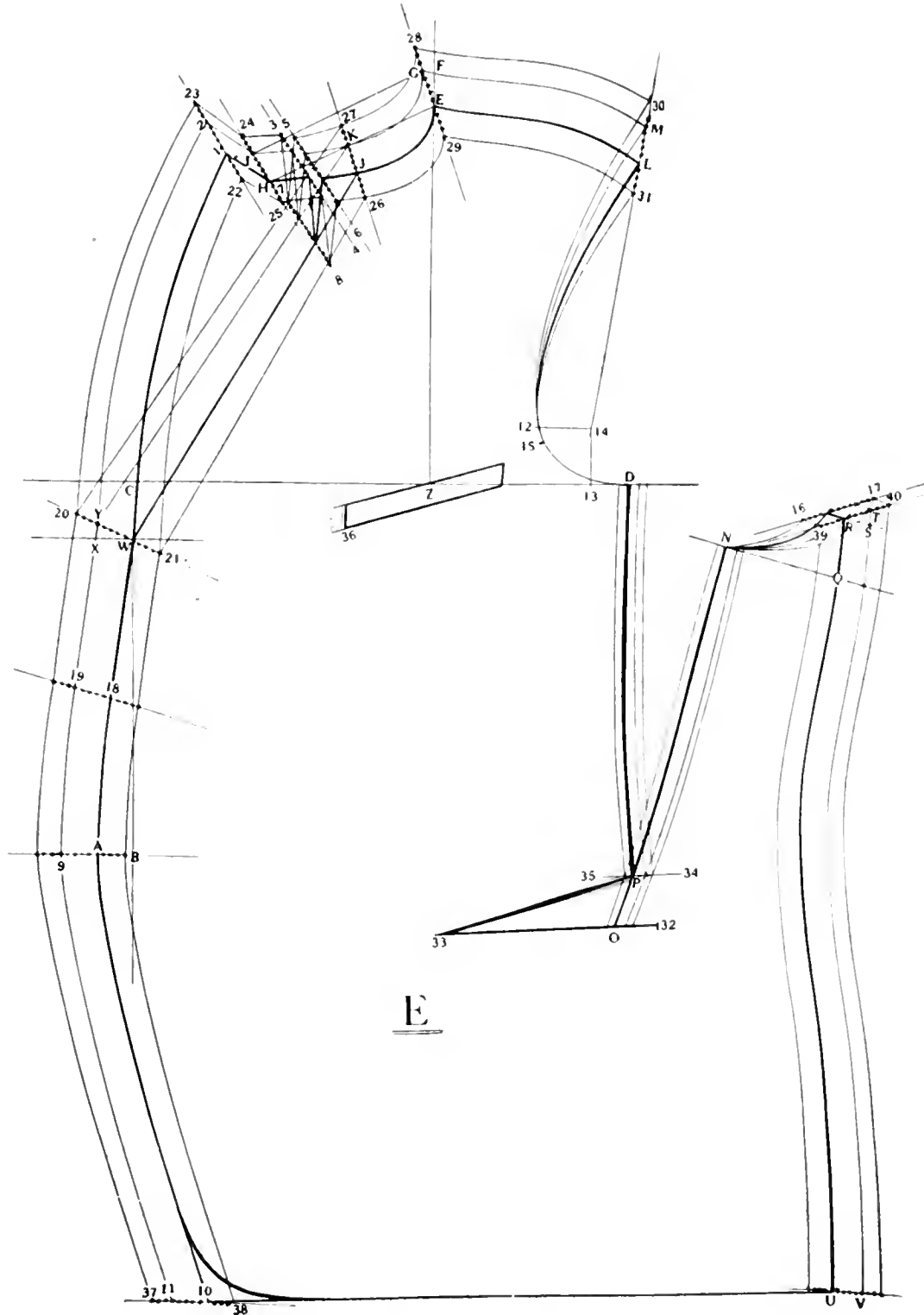

DIAGRAM E

Diagram E is the forepart of a fat man's Sack coat, 42 breast, 42 waist. In grading fat man's patterns start with 42 breast and space 4 sizes from 21 to 23 and divide these in 5 parts, making the 46 size 47. Extend the grades up to 50 and down to 38. By using the division of 5 it will decrease the larger sizes and increase the smaller ones. The back is graded the same as the ordinary Sack coat. The heavy line represents the 42 pattern. In squaring the breast line lay square back 1 inch from A to B at the waist line, which is $\frac{1}{4}$ of an inch for every inch of fat. Lay corner of square at end of lapel and square line W-X. Breast line C-D is then parallel with W-X. Shoulder point E is squared up from breast line Z. E to F is on 3rds, F to G on 8ths. Draw a line through E and G. 14 is $1\frac{1}{2}$ inch from 12 and 13. Draw a line from 14 through L. L to M is on 3rds. Line J-W is the break line of lapel on 42 size. Parallel line J-K by line E-G. Draw a line from E to H. Parallel line from G to I. G to I is $\frac{1}{4}$ inch more than E to H. Draw a line through H and I and parallel line I-2 by H-I. W to X is $\frac{7}{8}$ inch. X to Y is on 6ths. Draw a line through W and Y. A to 9 is $\frac{7}{8}$ inch. 10 to 11 is $\frac{7}{8}$ inch. D to X and P to O is the V taken out under the arm. Breast line N-Q is first drawn on the pattern with points N and D close together. Top of sidebody line R-S is parallel with N-Q. R to S is on 4ths and S to T on 12ths. Draw a line through R and T and parallel line 16-17 by R-T. U to V is on 4ths. The V under the arm moves backwards and forwards on 8ths. Line 34-35 is parallel with 32 and 33. The V moves forwards and backwards from P and O on 8ths. The first V in the 42 coat is parallel by the notch of lapel line 24-28. Line 3-4 is the front and line 5-6 the opening of the V. Line 7-8, the end of the V is parallel with line 3 and 4. Set spacer on 5 and divide all these spaces. Shoulder point E is 42, G is 47, 28 is 50, 29 is 38, L is 42, M is 47, 30 is 50, 31 is 38. Front W is 42, Y is 47, 20 is 50, 21 is 38, 10 is 42, 11 is 47, 37 is 50, 38 is 38. In the side—R is 42, T is 47, 40 is 50 and point 39 is 38. The pockets in the front at 33 are lengthened and shortened on 8ths.



FROCK COATS

The Frock coats are graded the same as the Sack coats starting with a size 38 pattern. Diagram F 1.

A to Z is on 3rds.

T to U is on 3rds and U to V on 8ths.

Draw line through T and V.

J to K is on 3rds and K to L on 3rds.

Draw line through J and L.

L to S is $\frac{1}{8}$ inch.

M to N is on 3rds and N to O on 12ths.

Draw line through M and O.

P is sleeve notch, square out to Q.

Q to R is on 6ths.

Draw line through P-R for sleeve notch.

C-D is the length of the 38 back.

C to G and D to E is on 6ths.

E to F is on 12ths.

Draw line through D and F.

THE SIDEBODY—DIAGRAM F 2.

Square up through point 5 top of sidebody by breast line W.

5 to 6 is on 12ths and 6 to 7 on 8ths.

Draw line through 5 and 7.

9 to 10 is on 3rds, 10 to 11 and 8 to 12 is on 6ths and 12 to 13 on 8ths.

Draw lines through 8 and 13 and 9 and 11.

8 and 9 is the 38 size and 13 and 11 is the 42 size.

5 is the 38 and 7 is the 42 size spaced.

Point 14 remains the same.

THE FOREPART—DIAGRAM F 3.

The heavy line represents the 38 size.

Square breast line X, Y, 42, 1.

Square up through shoulder point 23 by breast line 42.

23 to 24 is on 3rds.

24 to 25 is on 8ths.

Draw line through 23 and 25.

Draw line from 23 to 26.

Draw parallel line from 25 for 27.

25 to 27 is $\frac{1}{4}$ inch more than 23 to 26.

Draw line through 26 and 27 and parallel line 28 to 29.

The V is 36.

37 is parallel with line 26-27 and line 38 is parallel with 36-37.

Line 39-40 is parallel with line 36-37.

Line 27-29 is parallel with 26-28.

Break line 30-31 is parallel with line 23-25.

Y to 21 is $\frac{7}{8}$ inch.

21 to 22 is on 6ths.

Draw line through Y and 22.

18 to 19 is $\frac{7}{8}$ inch.

19 to 20 is on 6ths.

Draw line through 18 and 20.

18 is the 38 and 20 is the 42.

15 to 16 is on 4ths and 16 to 17 on 6ths.

Draw line through 15 and 17.

15 is the 38 and 17 the 42 size.

Line 1-2 is parallel with breast line.

1 to 2 is on 8ths and 3 to 4 is the same.

Point 32 is $1\frac{1}{2}$ inch up and back from the scye.

Draw a line from 32 through 33 for 34.

33 to 34 is on 3rds.

Divide all these spaces into 5 parts and the largest pattern spaced 42 will become size 43. See Diagram F for complete grade of Frock coats.

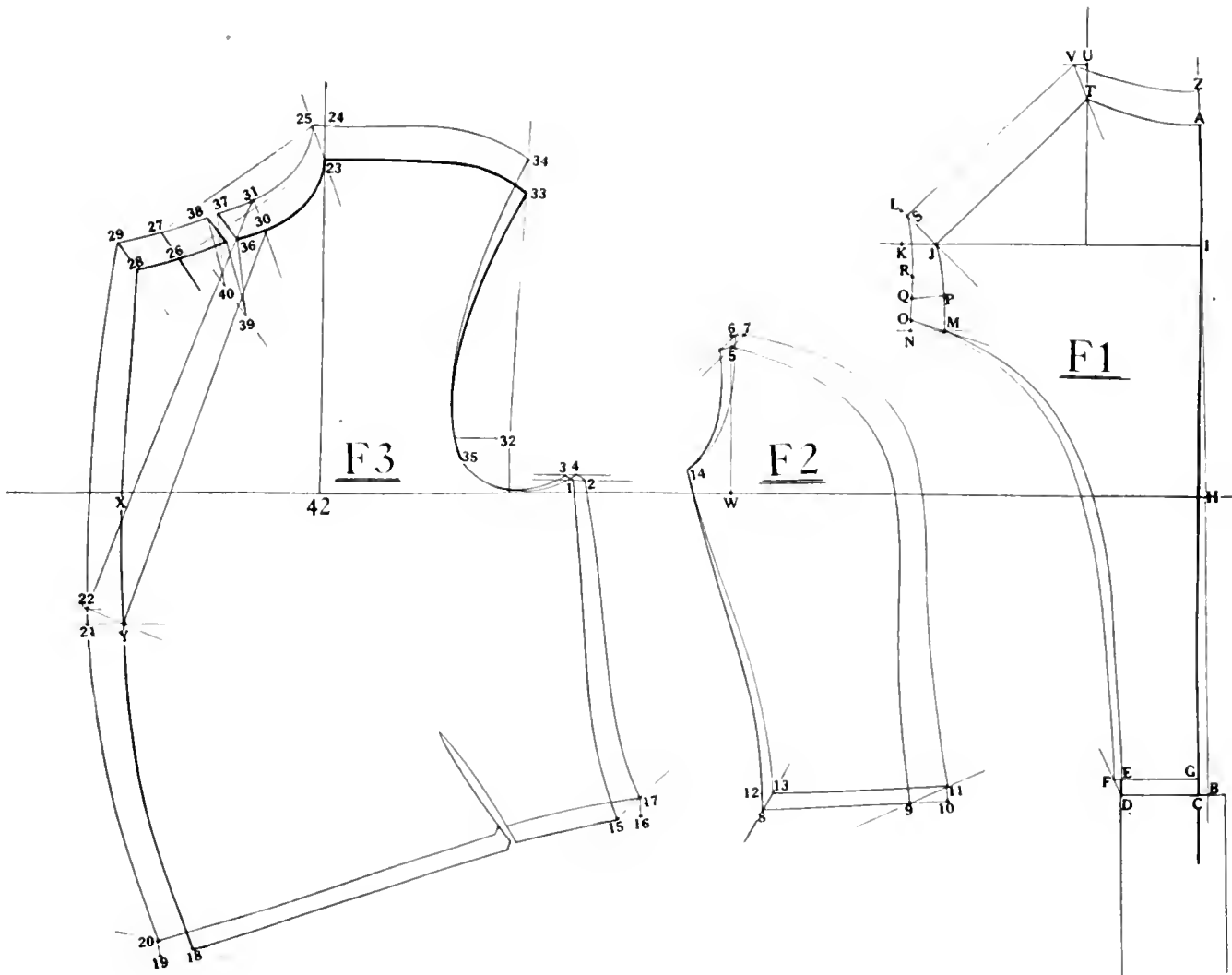

FROCK COAT. DIAGRAM F

COMPLETE GRADE.

By having studied the preceding diagram the student has familiarized himself with the general layout of the grade, so it will be unnecessary to go into all the preliminary details. The solid heavy lines represent the 38 size coat. Space out four sizes from 38 to 42, 19 to 21 on divisions, as explained in Diagram F, 1, 2 and 3. Divide these spaces into 5 parts, thus making the 42 size 43. Extend all lines up and down and continue the spaces up and down to the largest and smallest pattern desired. In the pattern the largest is 46 and the smallest is 34. The waist length of the back is lengthened and shortened on 6ths. The foreparts and sidebodies are lengthened and shortened on 6ths, which will leave the length of the skirts the same.

THE SKIRT.

A, B, C and D is the 38 skirt. Draw a straight line from A through B for points E-G. It is easier to grade a square corner than one that is round, so for the beginner it is better to square out the corners and grade them square and afterwards round the corners. The bottom of the skirt rounds back to point J, but in this case it has been squared down to point D. Square forward and back from D. A line may be drawn just above the round of the skirt and graded if so desired. The increase of the skirt in width from B to E and D to F is $1\frac{3}{4}$ inch or two inches less the increase of the back at waist line. Divide the distance between B and E, D and F, into five parts, go forward 3 spaces from E to G and F to H for the 46 size and come back four spaces from B to I and D to J for the 34 size. Shape top to each point in front from point K, top of hip.

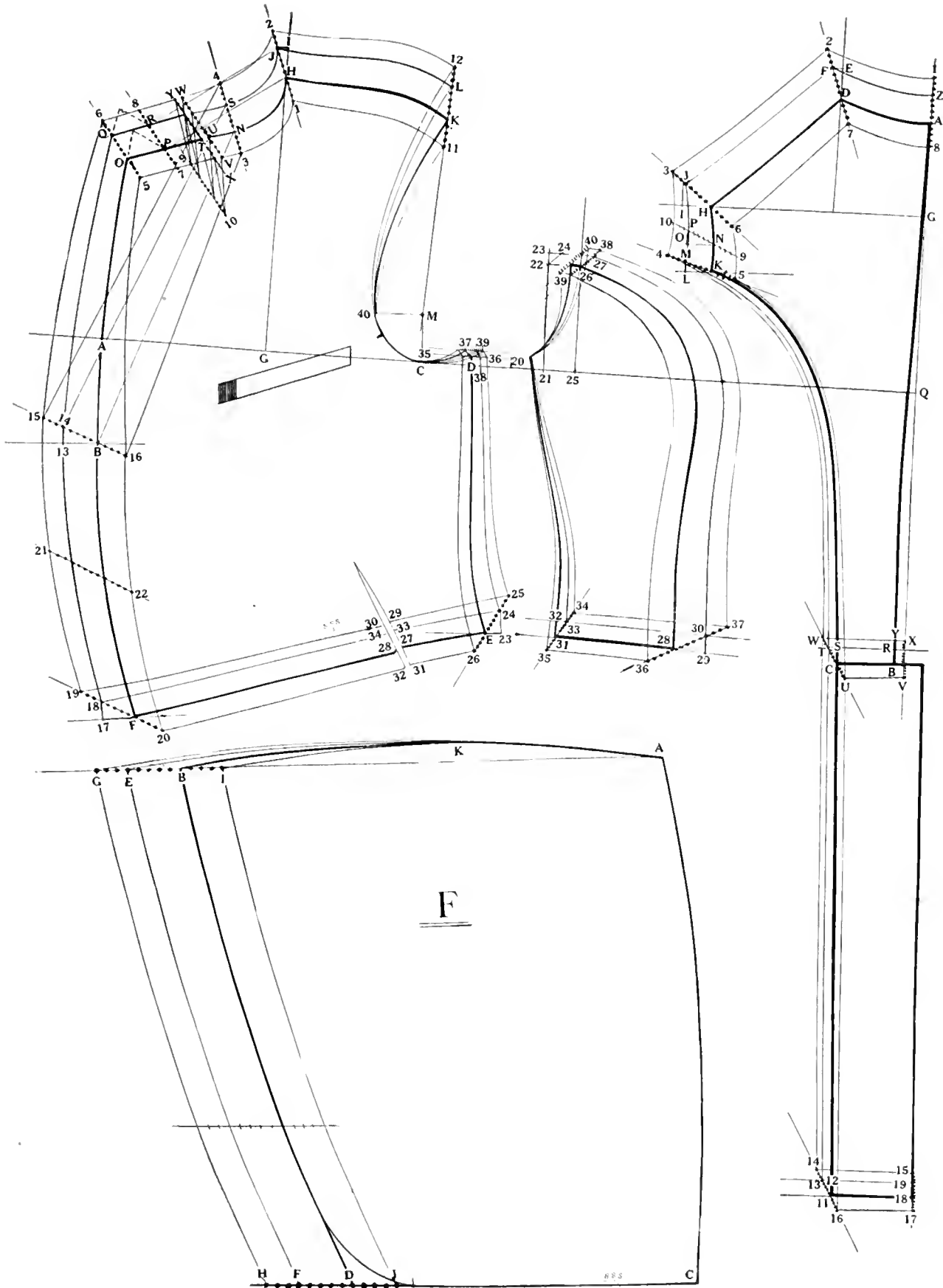

DIAGRAM G

THE PALETOT.

The Paletot is graded the same as the Frock Coat. Start grading with a size 40 pattern and space off four sizes from 40 to 44. Use 20 to 22 on divisions.

A, B, O, L, F, G is the size 40 back.

A to V is on 6ths.

G to H is on 6ths and H to I on 8ths.

Draw line through G and I.

F to J is on 3rds and J to K on 3rds.

Draw line through F and K.

K to 10 is $\frac{1}{8}$ inch.

L to M is on 3rds and M to N on 12ths.

5 is sleeve notch. Square out to 6.

6 to 7 is on 6ths. Draw line through 6 and 7.

B to U and O to P is on 6ths.

P to Q is on 12ths. Draw line through O and Q.

Divide all these spaces into 5, go up to 48 and down to 36, or up and down to any other sizes desired.

THE SIDEBODY.

Square up through top of sidebody point 12 from breast line 11.

12 to 13 is on 12ths and 13 to 14 is on 8ths.

Draw line through point 12 and 14 for 15 and 16, then draw parallel line 17 and 18 for the seam.

16 is size 36, point 12 is 40, point 14 is 45 and point 15 is size 48.

Points 20 and 19 is the 40 sidebody.

19 to 21 is on 3rds.

21 to 22 and 20 to 23 is on 6ths.

23 to 24 is on 8ths.

Draw line through 20 and 24 for 25 and 26.

Draw line through 19 and 22 for 27 and 28. Divide into 5 parts.

26-27 is size 36, 20-19 is size 40, 24-22 is size 45 and 25-28 is size 48.

Point 29 remains stationary.

THE FOREPART.

Square breast line A, B, C, D.

The heavy line is the size 40 coat.

Square up from breast line C through shoulder point I.

Point 14 is $1\frac{1}{2}$ inch up and back from armseye.

Draw line from 14 through 15.

15 to 16 is on 3rds.

I to J is on 3rds and J to K on 8ths.

Draw a line I and K.

Draw a line from shoulder point I to notch of lapel 2,

then draw a parallel line from K for 3.

3 to K is $\frac{1}{4}$ inch more than I to 2.

Point N is the V for the 40 coat.

Draw parallel line with line L-M up and down from O.

Lines R-S and T-U are parallel with O-P.

Draw line through 2 and 3 and parallel lines 1 and 6.

V to W is $\frac{7}{8}$ inch and W to X is on 6ths.

Draw line through V and X.

9 to 10 is $\frac{7}{8}$ inch and 10 to 11 on 6ths.

Draw line through 9 and 11.

Line 42 is parallel with line 12-13.

D is the size 40 coat.

Line E-F is parallel with breast line. The increase from D out to the 44 size is on 8ths.

30 is the side seam; 27 and 22 is the forepart and skirt of the 40 coat.

A V is cut out as from 27 to 22 extending up to 40.

22 to 23 is on 8ths and 23 to 24 on 6ths.

Draw line through 22 and 24.

Parallel 27 with line 25 and 26.

Line 40 is paralleled by 25 and 26.

Divide distance between 22 and 24 into 5 parts, then run up and down to 26 and 25. Divide lines 28-29 and line 40 with same spaces.

30 to 31 is on 4ths and 31 to 32 on 6ths.

Draw line through 30 and 32 and divide into 5 parts, then space up and down for the 48 and 36 sizes.

The skirt runs from 22 through 30 to 35 and down to 43.

35 to 36 is on 6ths and 36 to 37 is $\frac{7}{8}$ inch.

Draw line through 35 and 37 and divide into 5 parts, go up to 38 for 48 size and down to 39 for the 36 size.

Line 43 is parallel with line 38-39 and the divisions are the same.

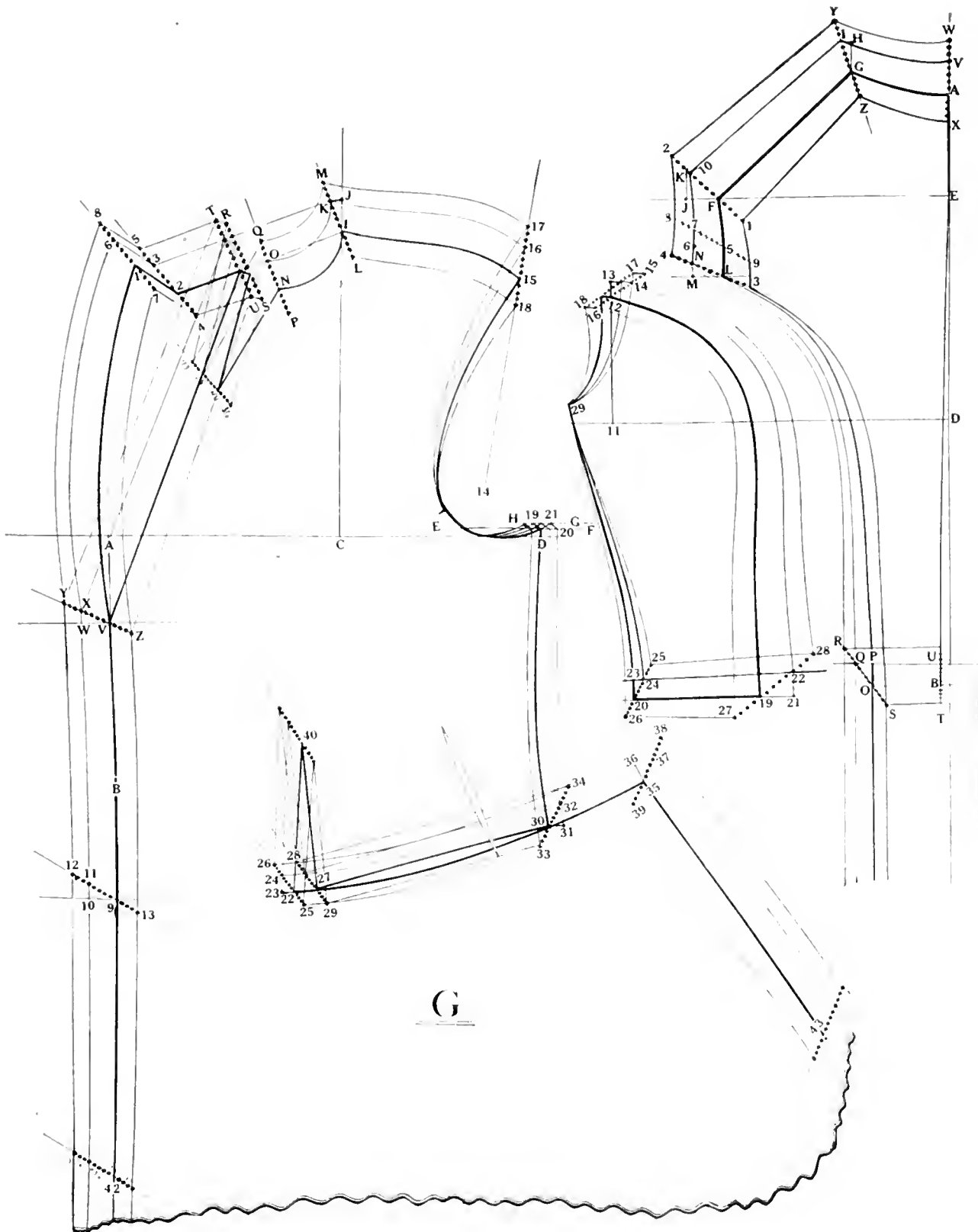

DIAGRAM H

THE RAGLAN.

The Raglans are graded the same as the regular Sack coats. Use a size 40 to grade from. The heavy lines indicate the 40 size pattern.

THE BACK.

A to V is on 3rds.
 B to C is on 3rds.
 C to D is on 8ths.
 Draw line through B and D.
 Point F is the sleeve notch.
 Square across at point F.
 F to G is on 3rds and G to Q on 6ths.
 Draw line through F and Q.
 Reduce $\frac{1}{8}$ inch at point Q.
 Line H-I is parallel with line E, F.
 H to I is on 3rds and I to J on 12ths.
 Draw line through H and I.
 Draw line M-N parallel with line K-L.
 O to P is on 3rds.
 2 to 3 is on 3rds.
 Divide all these spaces into 5 parts.
 W, T, R, N, K and 4 is the 48 size.
 V, D, Q, P, I and 3 is the 45 size.
 X, U, S, M, L and 5 is the 36 size.
 The bottom part is graded the same as the regular Sack coat.

THE FOREPART.

Draw breast line across at top of sidebody.
 Square up through shoulder point 6 from breast line C.
 6 to 7 is on 3rds and 7 to 8 is on 8ths.
 Draw line through 6 and 8.
 6 is forwards of 11 and points 7 and 8 forwards of 12.
 Draw line from 6 to 9 and parallel line from 8 for 10.
 8 to 10 is $\frac{1}{4}$ inch more than 6 to 9.
 Draw line through 9 and 10 and parallel line 14-15.
 The lines for the V's are parallel with front of notch line 9-10. The bottom of the V is on a parallel with the top.
 25 is end of the roll and 18 is the break of roll at neck.
 Parallel break line 18-19, 20 and 21 with line 6-8 front shoulder points.
 25 to 26 is $\frac{7}{8}$ inch.
 26 to 27 is on 6ths.
 Draw line through 25 and 27, space into 5 parts, go up to 28 for the 48 size and down to 29 for the 36 size.
 30 is the top of sidebody of the 40 size.
 30 to 31 is on 4ths.
 31 to 32 on 12ths.
 Draw line through 30 and 32 and divide up and down for all sizes.
 Draw parallel line 37-38 for the seam.
 34-38 is size 36, 30-35 is size 40, 32-36 is size 45 and 33-37 is size 48.
 Point at 39 is on 4ths and at 40 same as at breast line.

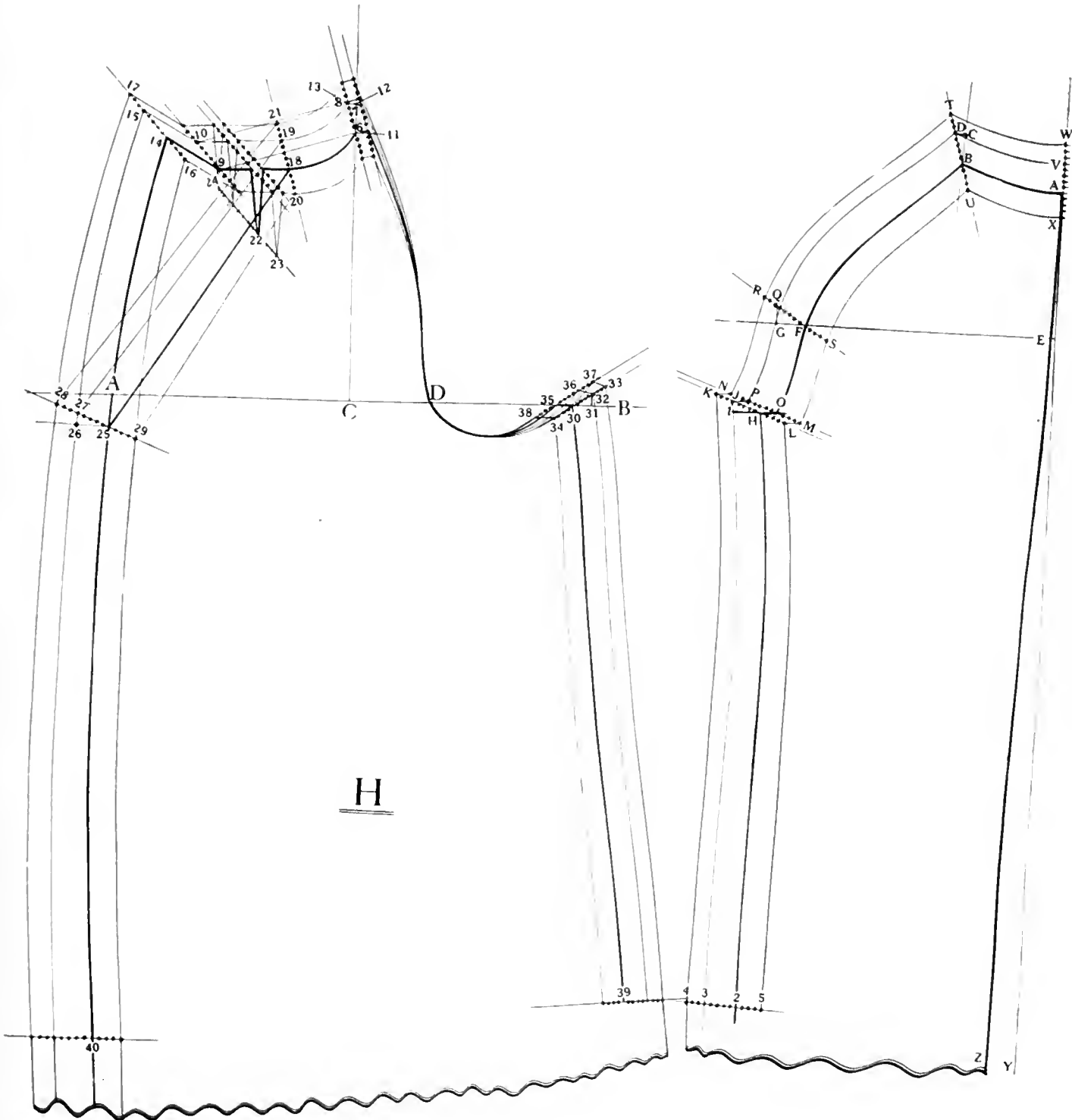

DIAGRAM I

THE FOREPART OF DOUBLE BREASTED FROCK

The Double Breasted Frock is graded the same as the Single Breasted Frock. The heavy line is the 38 size Forepart.

Square breast line and square up line C through front shoulder point.

Point Z is $1\frac{1}{2}$ inch from 24 and 25.

Draw a line from Z through F.

E to I is on 3rds and I to J on 8ths.

Draw a line through E and J.

Draw a line from E to D and parallel a line from J for point K.

J to K is $\frac{3}{8}$ inch more than E to D.

Draw line through D and K.

A to L is $\frac{7}{8}$ inch and H to M is $\frac{7}{8}$ inch.

M to N is on 6ths. Draw line through H and N.

G to Q is on 4ths and Q to R on 6ths.

Draw a line through G and R.

B to 1 is on 8ths and 4 to 5 on 8ths.

Line 6-7 is parallel with breast line.

F to 21 is on 3rds.

8 and 12 is the break line of lapel.

Parallel 8-9 by line 19-20.

Line 14-15 is parallel with line O-P.

The lapel is graded only on length according to length of forepart.

The collar is increased 1-16 inch in front and 2-16 in the back, in all 3-16 inch for each size.

COLLARS.

Diagram 1.

Collars for ordinary Sack and Frock coats will increase in length 3-16 inch for every size. Of this 1-16 goes to the front end and 2-16 to the back.

Diagram 2.

Convertible collars increase in size $\frac{1}{5}$ inch for every size. Of this $\frac{1}{3}$ is added in front and $\frac{2}{3}$ in the back.

Diagram 3. Blouse Collars.

The increase of neck is $\frac{2}{5}$ inch for each size of breast, hence the increase of half of the collar is $\frac{1}{5}$ inch, which is all added in the back.

Diagram 4.

The Ulster collar is graded the same as the Blouse collars. The increase is $\frac{1}{5}$ inch for every size of breast, all added in the back.

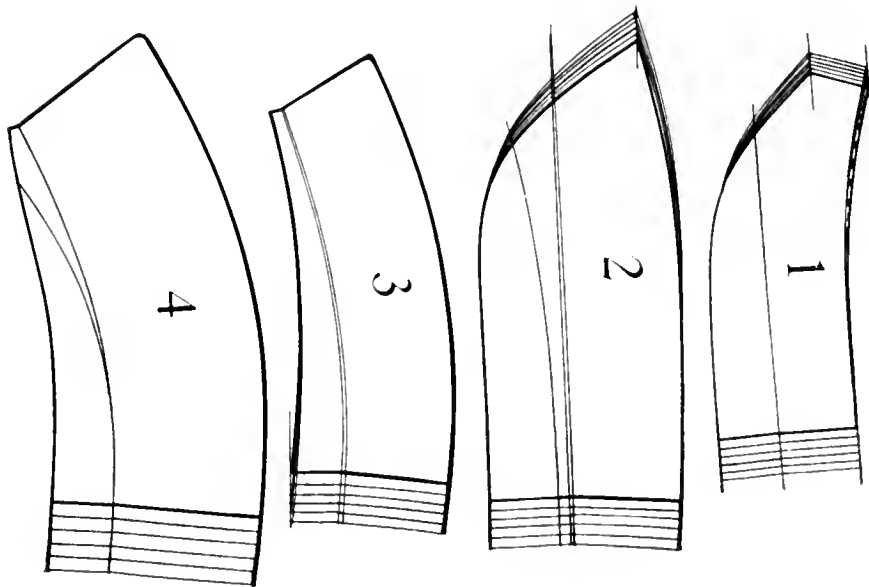
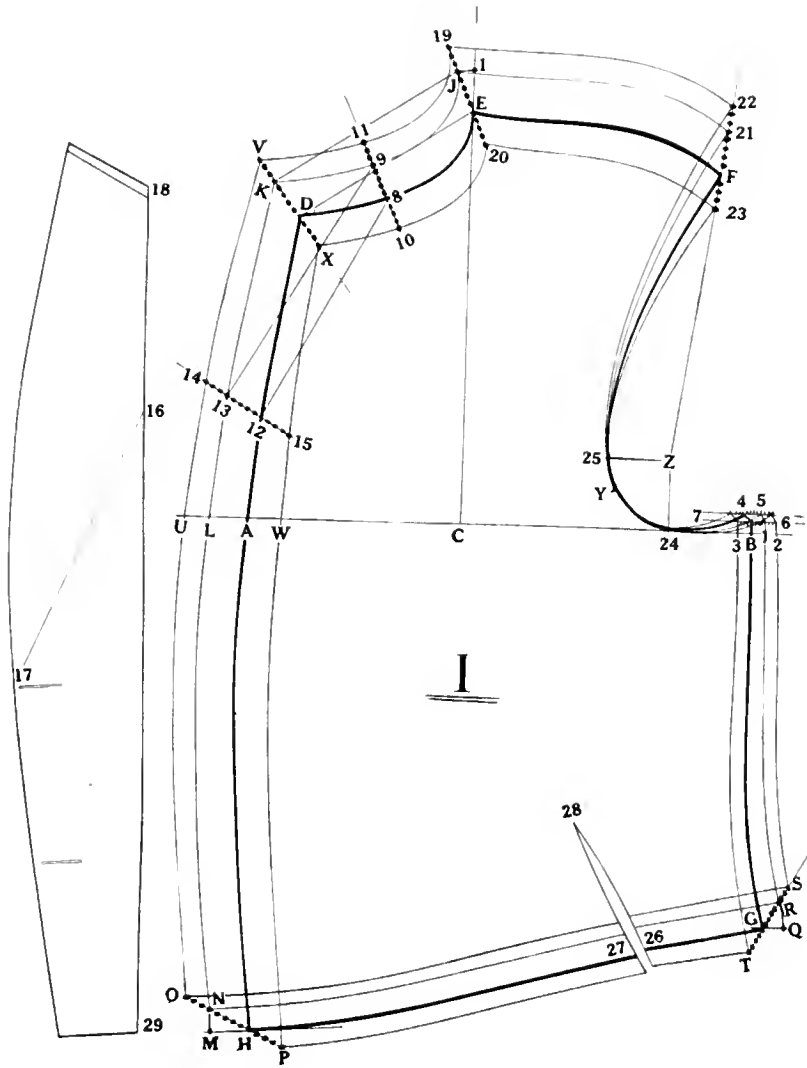

DIAGRAM J

THE DRESS COAT FRONT.

The Dress Coat is graded the same as the regular Frock Coats. The heavy lines represent the 38 size from which to grade.

Draw breast line and square up through front shoulder point B from breast line A.

Q is $1\frac{1}{2}$ inch up and forwards from armseye. Square up from Q through O.

O to P is on 3rds.

B to C is on 3rds and C to D on 8ths.

Draw line through B and D.

E is the dart. Parallel up and down from E by front of shoulders B-D.

F is front of dart. Parallel F up and down for 8-11 by line 14-15.

Parallel line 36-37 by line 8-11 and line 20-21 is on a parallel with line 36-37.

Draw a line from B to C and parallel a line from D for K.

D to K is $\frac{1}{4}$ inch more than B to C.

Draw a line through C and K and parallel a line from H for L, 12 and 13.

Lines K-J, 10-11 and 9-8 are on a parallel with line G, F.

Lines K-L, 10-13 and 12-9 are parallel with G-H.

S to T is $\frac{7}{8}$ inch and T to U is on 6ths.

Draw a line through S and U for points 24 and 25.

Line V, W is on a parallel with line S, U.

Line 28 to 29 is up on 6ths and forwards on 8ths.

Lines 32-33 and 34-35 are parallel with line 30-31.

R to X is on 4ths and X to Y on 6ths.

Draw a line through R and Y for points 22-23.

2 to 3 and 6 to 7 is on 8ths.

Divide into five parts the same as on the Frock coats.

Back and sidebody are the same as on the Frock coats.

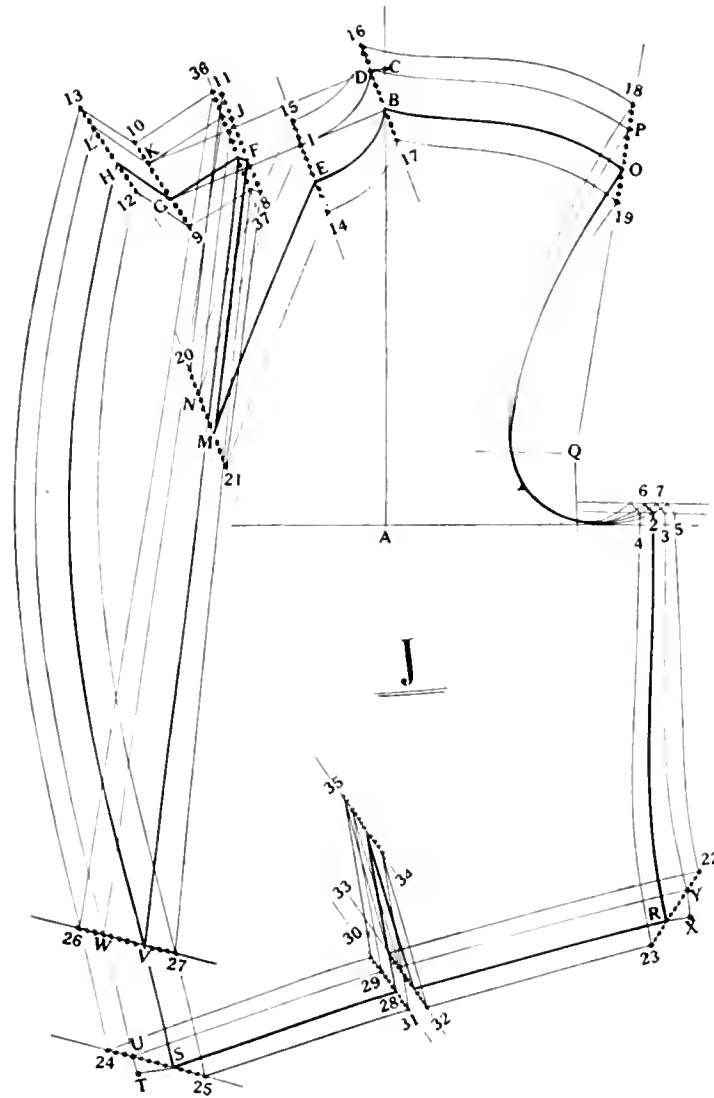

DIAGRAM K

Diagram K represents the front of a policeman's overcoat with no V taken out at neck gorge. The heavy line represents the 40 size forepart.

Draw the usual breast line B, E and I.

Line A, B, C is the front center.

Square up from breast line E through front shoulder point F.

F to G is on 3rds and G to H on 8ths.

Draw a line through F and H.

Draw a line from F to A and a parallel line from H for point I.

H to I is $\frac{3}{8}$ inch, which together with the $\frac{1}{4}$ inch increase of the width of back at top makes it $\frac{5}{8}$ inch increase of the neck gorge.

Draw a line through A and I and parallel J for K.

Line D, O is $2\frac{1}{4}$ inches below B.

D to O is $\frac{7}{8}$ inch. Draw front center line from I through O for point Q.

X to Y is $\frac{7}{8}$ inch.

Line R, S, T is the V taken out.

Measure distance between first center line C to second center line Q at bottom of forepart.

From U to V is the same as C to Q and from R to C is the same as C to Q.

V to W and C to 8 is on 6ths.

Draw line from U through W and from R through C.

S to 6 is on 6ths and 6 to 7 is $\frac{7}{8}$ inch.

Draw line through S and 7.

Line T-9 is parallel with line S-7.

I to K is the same as A to J.

Point Z is $1\frac{1}{2}$ inch forward and up from armseye.

Draw a line from Z through L.

L to M is on 3rds.

1 to 2 is on 8ths, 3 to 4 is on 4ths and 4 to 5 on 6ths.

Draw line through 3 and 5, divide all these spaces into five parts.

The back, sidebody and skirts are graded the same as the regular Frock coats.

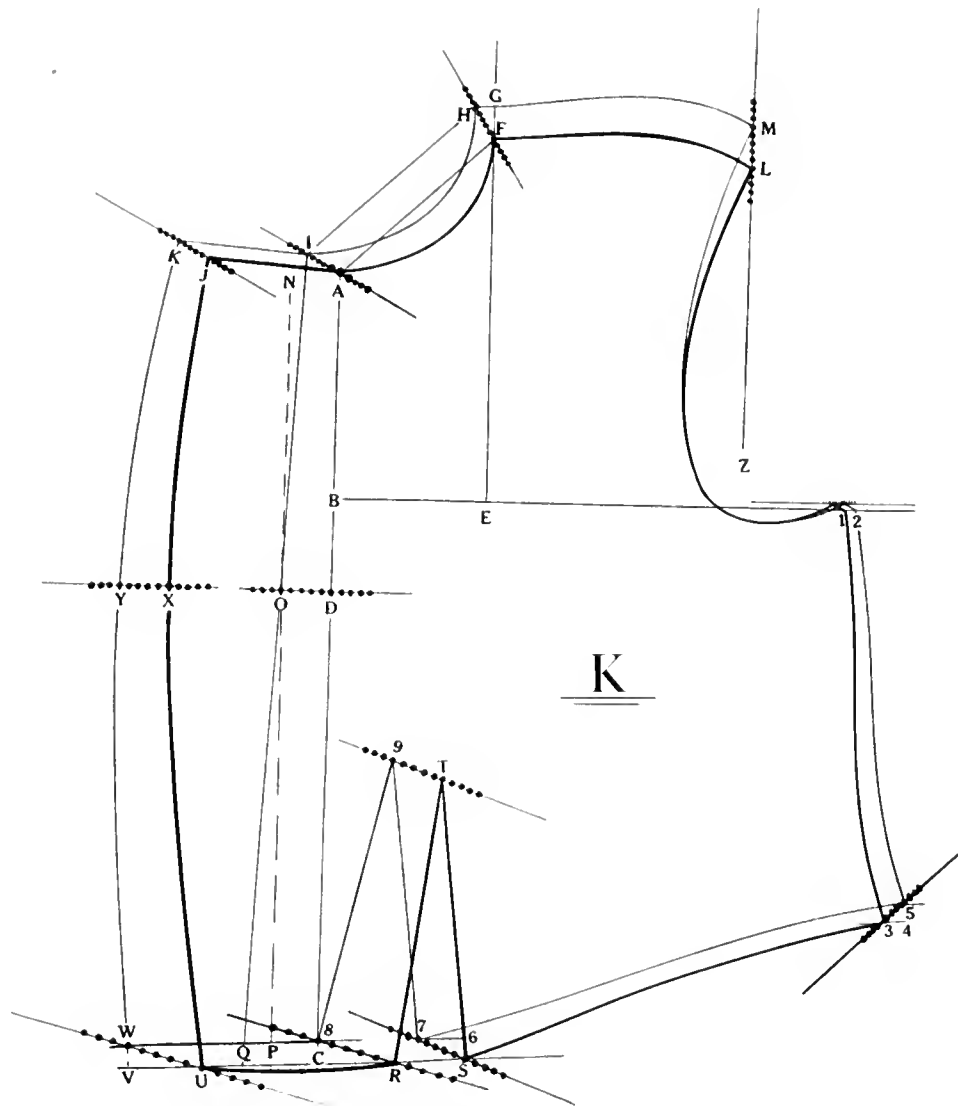

DIAGRAMS L-M

Diagram L is the Dress Coat Skirt. M, N, O and P is the 38 size skirt.

Square out from M through N and from O through P. P to R is on 4ths and N to Q is $1\frac{1}{4}$ inch or whatever the increase of the forepart and sidebody may be. Divide space into 5 parts, then go forward to S and T for the 46, and back to U and V for the 34 size.

Shape top part from W forward to all the different points.

Diagram M is the skirt for the double breasted Frock. A, B, C and D is the 38 size skirt.

Draw a line from A through B.

B to E and C to F is 2 inches less the increase width of back on 12ths.

Divide distance B to E and C to F into 5 parts, then go forward to G-H for 46 and back to I-J for 34 size.

Shape top of skirt from point K, center of hip forward to all the different sizes.

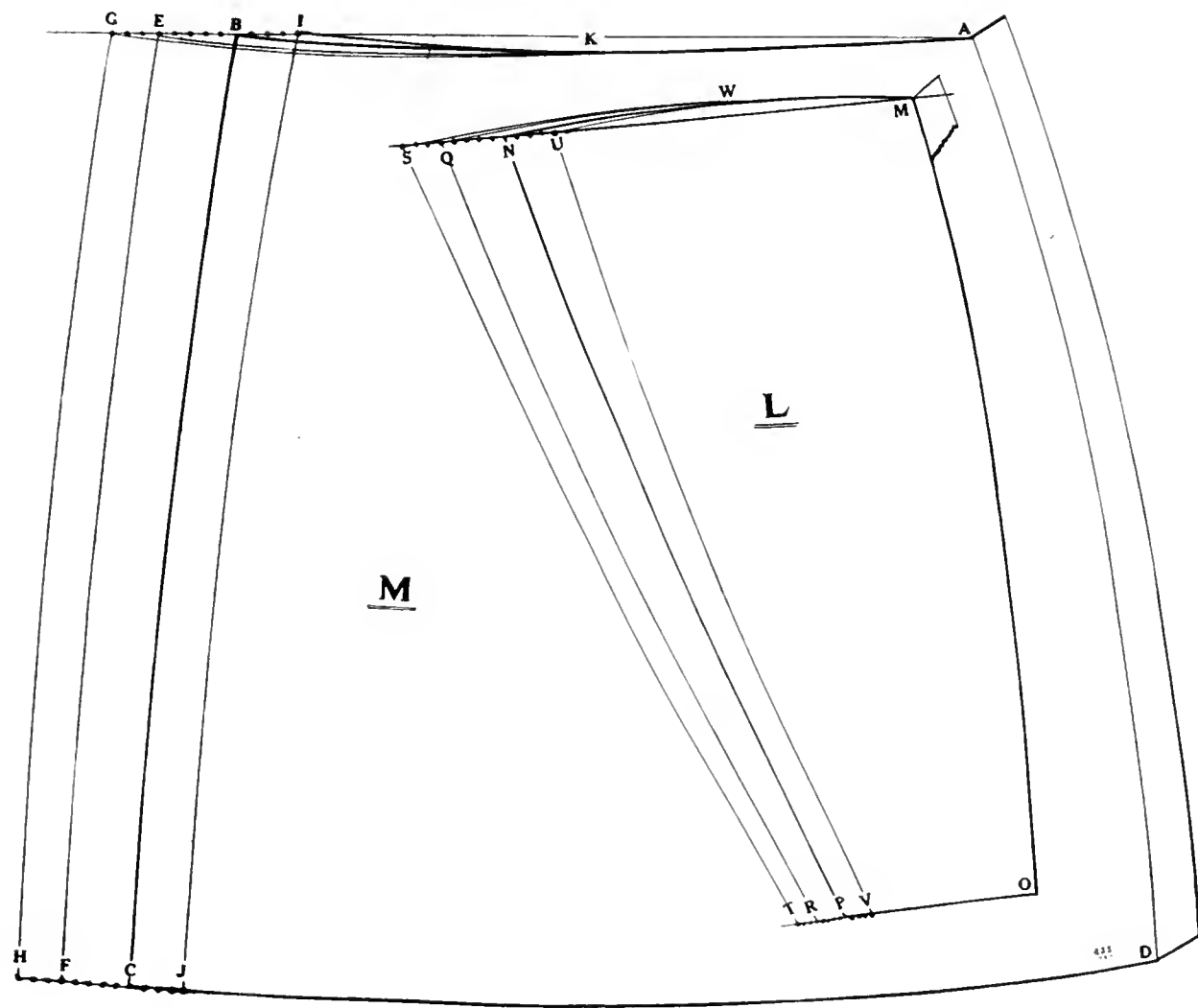

DIAGRAM N

THE SLEEVE.

The heavy line represents the 38 size sleeve.
 Draw a straight line A, B, C through front center of sleeve.
 Square a line through D from C.
 D to E is $\frac{3}{4}$ inch and E to F is on 6ths.
 Draw a line through D and F for G and H.
 M is halfway between D and C on 38 size and N is halfway between C and E, the spaced 42 size. Square up M and N.
 Square up and down a line at I where sleeve top crosses line C, M, N.
 I to J is on 6ths.
 R to O is on 4ths.
 Draw a line through O and P for T and S.
 U is halfway between P and D, and V is halfway between O and F.
 Draw a line through U and V.
 U-V is the same as D-F.
 Y to 10 is on 8ths. Divide spaces into 5 parts. Go out for the larger and in for the smaller sizes.
 The 38 size undersleeve is shown by lines 8, 9, Y and 2.
 Parallel line 2, 3, 4 and 5, also line 6-7 by top sleeve line G-H.
 Space the undersleeve on line 2-3 the same spaces as top sleeve on line D, F.
 The undersleeve at bottom is spaced the same as the top sleeve.

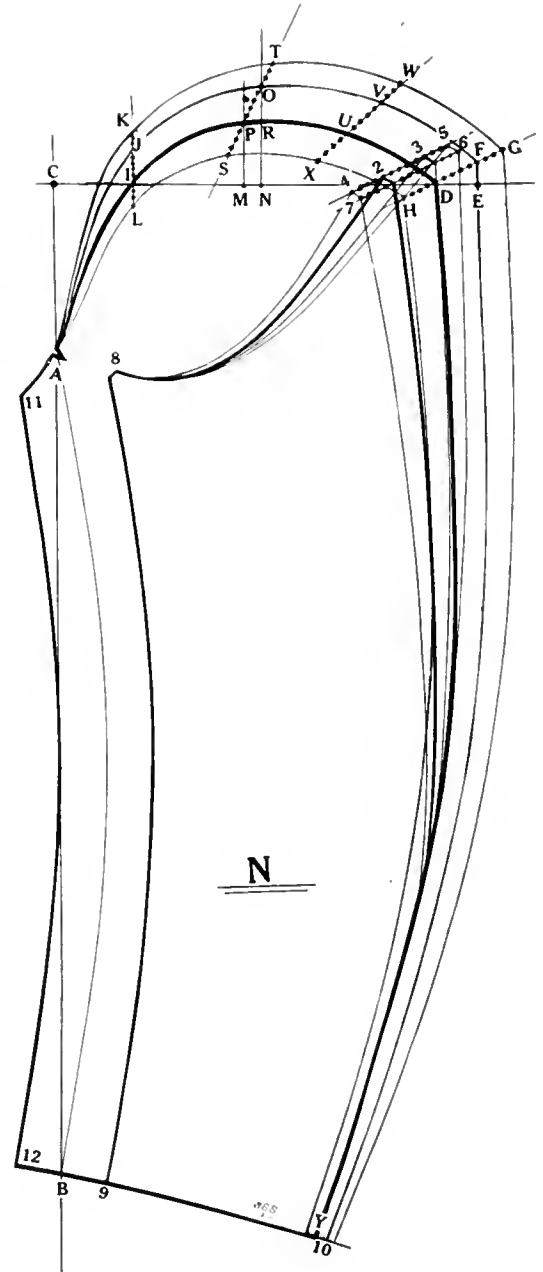

DIAGRAM O

THE RAGLAN SLEEVE.

Draw front center line A, B and C.
Square across from point D outside corner of the 40 size
outside top sleeve.

D to E is $\frac{3}{8}$ inch and E to F is on 6ths.

Draw line through D and F for G and H.

Line 15-16 is parallel with line H-G.

Point K is top of 40 sleeve. Go up from K on 3rds and
back on 6ths for point L, which is top sleeve of the 44
spaced sleeve. Run line through K and L and divide
into 5 parts. Go up to N for the 48 and down to M
for the 36 size.

Lines O, P, Q are parallel lines with line M-N.

At hand, point T, the increase is on 16ths.

THE INSIDE TOP SLEEVE.

The top part is at point 6.

Draw a parallel line 6-7 by front center line.

6 to 7 is on 3rds and 7 to 8 on 8ths.

Draw a line through 6 and 8. Divide into 5 parts up to
10 for 48 and down to 9 for 36 size.

Lines 11, 12, 13 and 14 are all parallel lines with line
9-10.

Draw line W-X from 19 to D.

W to X is $\frac{3}{8}$ inch. Divide into 5 parts out to Z for the
48 and back to Y for the 36 size.

Lay pattern top at 8 and shape down to X, which will
give distance from 2 to 3. Shape outside sleeve by
laying top of pattern at L. Shape down to F, this will
locate point 16.

The increase and decrease at hand point V is on 16ths.

The undersleeve is graded the same as for the regular
coats.

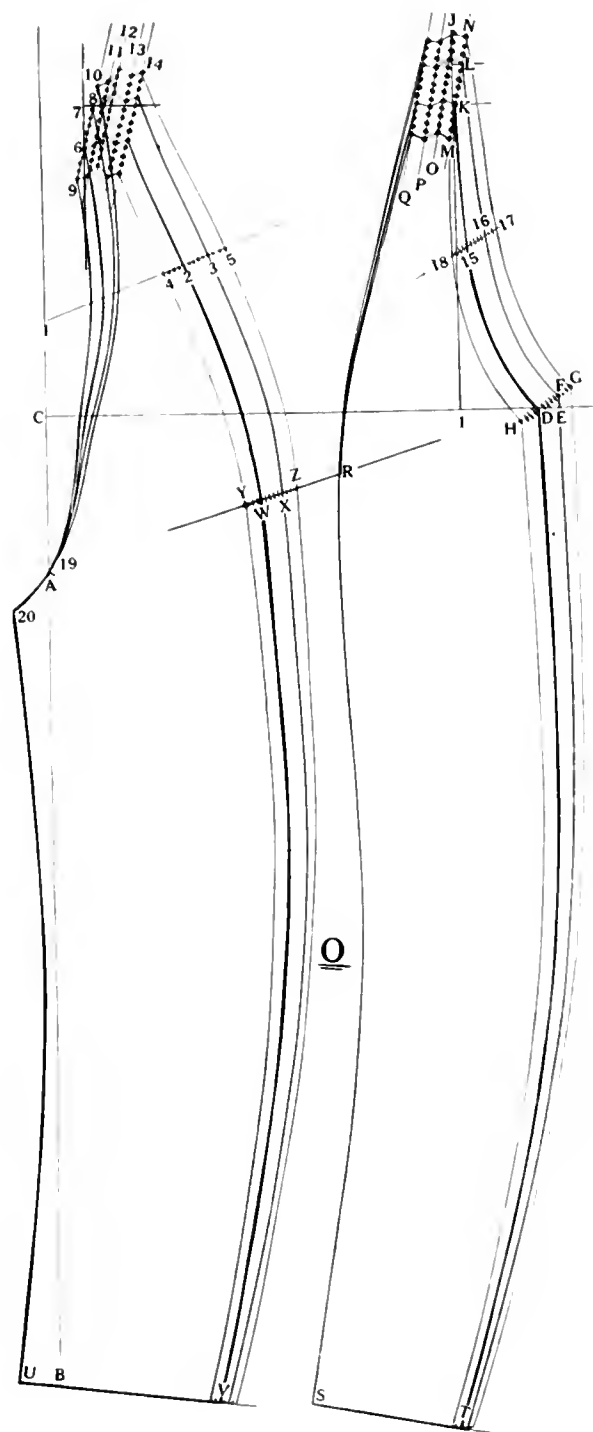

DIAGRAM P**VESTS.**

The grading of vests is on the same principle as the coat. In this grade we start with the normal vest. The heavy line notates the 38 size normal vest. Start with the backpart.

A to J is on 3rds.

B to K is on 3rds and K to L on 8ths.

Draw a line through B and L.

C to M and M to N is on 3rds.

Draw a line through C and N.

N to R is $\frac{1}{8}$ inch.

D to Q is on 3rds and Q to S is $\frac{1}{8}$ inch less.

E to O and F to P is 1 inch.

Divide all these points into 5 parts. Go up 3 points more for 46, and down 4 more points for 34 size.

THE FOREPART.

The heavy line indicates the 38 front part.

Square up from breast line 6 through front shoulder point 7.

Point 15 is $1\frac{3}{4}$ inch up and back from armseye.

Draw a line from 15 through 16.

16 to 17 is on 3rds.

7 to 8 is on 3rds and 8 to 9 is on 8ths.

Draw a line through 7 and 9 and parallel 10-11 by 7-9.

3 to 4 is $\frac{3}{4}$ inch and 4 to 5 is on 6ths.

Draw a line through 3 and 5.

18 to 21 and 19 to 22 is $\frac{3}{4}$ inch.

20 to 23 and 1 to 24 is $\frac{1}{4}$ inch.

Divide all these spaces into 5, go out three spaces for size 46 and go in four spaces for 34 size.

The neck piece is lengthened on 3rds plus $\frac{1}{4}$ inch from 12 to 13.

9-14 is parallel with 11-12.

Draw a line through 12 and 14 and parallel 13, giving all the points for the different size of neck piece.

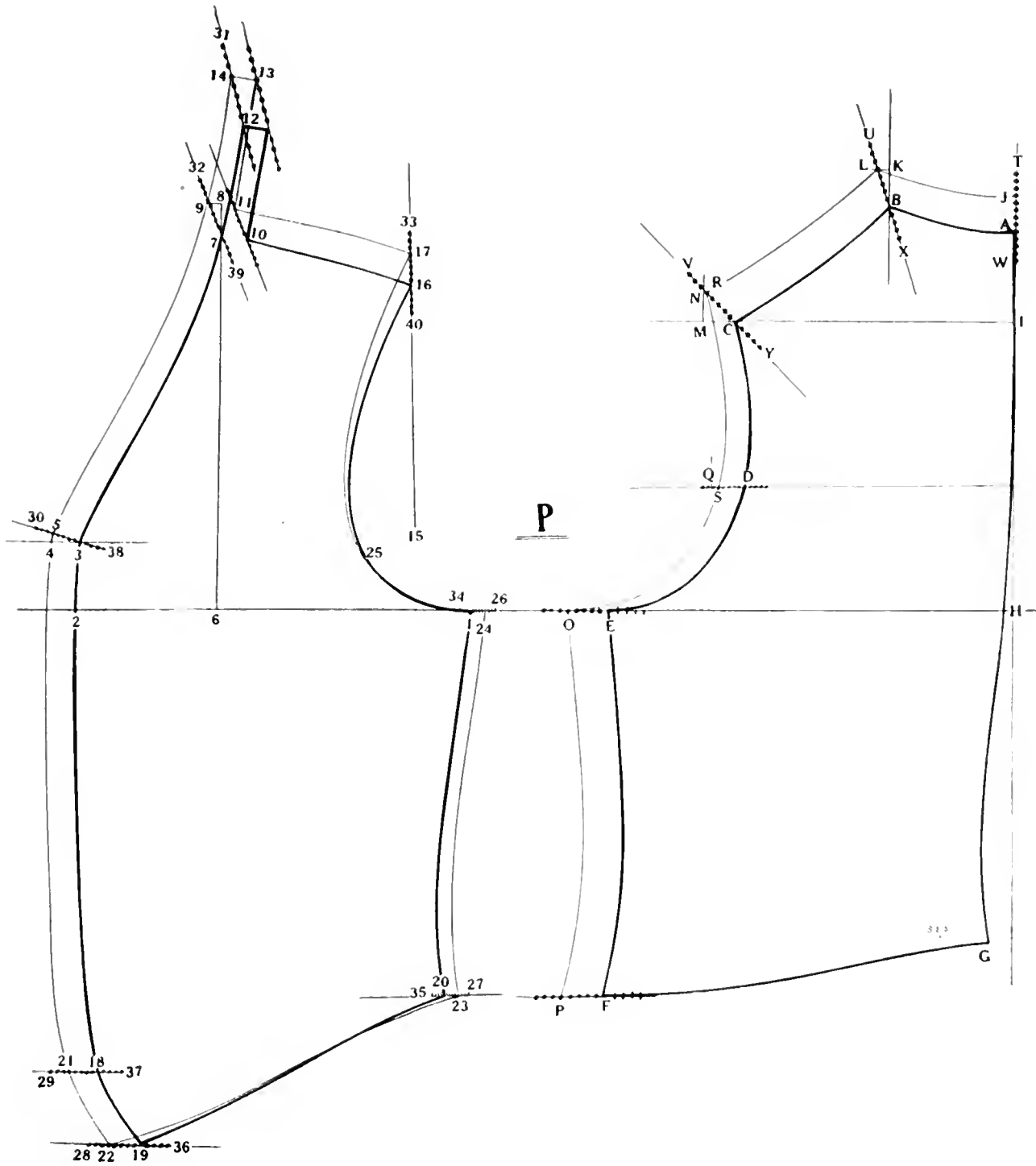

DIAGRAM Q**FAT MEN'S VEST.**

In this diagram we have the vest for the fat man, breast 42, waist 42. The heavy lines indicate the size 42 breast vest.

THE BACKPART.

A to J is on 3rds.

B to K is on 3rds and K to L is on 8ths.

Draw a line through K and L.

C to M and M to N is on 3rds.

Draw a line through C and N.

N to O is $\frac{1}{8}$ inch.

D to P is on 3rds less $\frac{1}{8}$ inch.

E to Q and F to R is 1 inch.

Divide all these spaces into 5 parts. Go out 3 spaces for 48 and down 4 spaces for the 38 size.

THE FOREPART.

Come back at waist line 1 inch as from S to T and square back from U for breast line.

Square up from breast line 1 through shoulder point 2.

Point 5 is $1\frac{3}{4}$ inch up and out from armseye. Draw a line from 5 through 7.

7 to 8 is on 3rds.

2 to 3 is on 3rds and 3 to 4 on 8ths.

Draw a line through 2 and 4.

U to 9 is $\frac{3}{4}$ inch and 9 to 10 is on 6ths.

Draw a line through U and 10.

11 to 12 and Z to 13 is $\frac{3}{4}$ inch.

V to 15, W to 16, X to 17 and Y to 14 is $\frac{1}{4}$ inch.

Divide all these spaces into 5 parts, come out 3 parts for 48 and down 4 parts for 38 size. 18 to 19 is $\frac{1}{4}$ inch.

Divide into 5 parts.

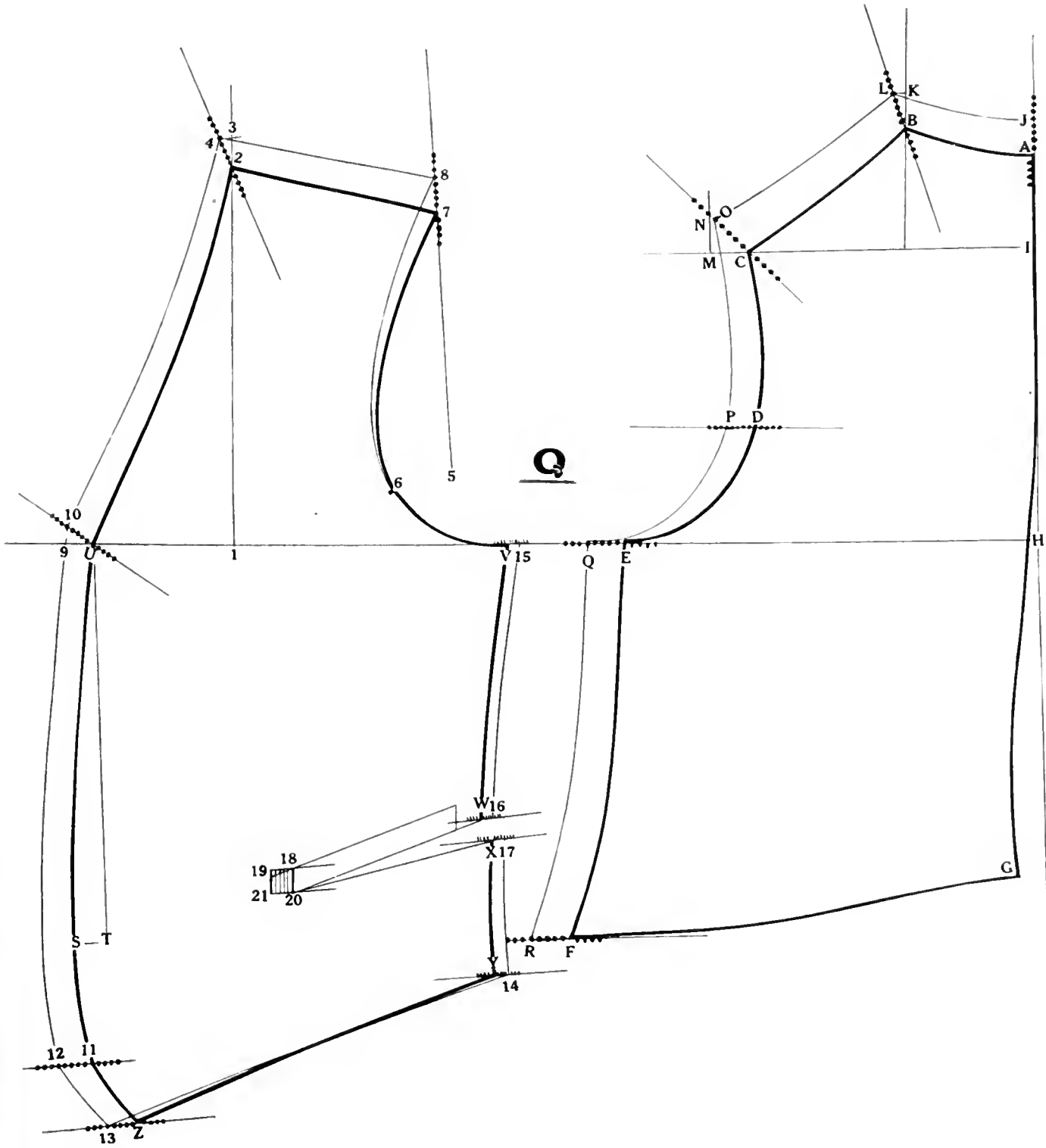

DIAGRAM R

TROUSERS.

In this diagram we have the normal trousers. The heavy outline is that of the pattern from which to grade. Waist 34, seat 39, knee and bottom to prevailing style.

A to B is the center line.

C to N is $\frac{1}{2}$ inch and N to O $\frac{1}{2}$ inch.

Draw a line through C and O.

D to P is $\frac{1}{2}$ and P to Q $\frac{1}{2}$ inch. Draw a line through D and Q.

E to R and J to U is $\frac{3}{8}$ inch.

I to T is $\frac{1}{2}$ inch and F to S is $\frac{5}{8}$ inch.

32 to 33 is $\frac{1}{2}$ inch.

Line 32-33 is 5 inches down from line F, S.

J to U is $\frac{3}{8}$ inch and K to V is 5-16 inch.

L to X and G to W is on 8ths.

M to Y and H to Z is on 16ths.

Divide all these spaces into 5 parts. Go out 3 spaces for waist 42 and come back 4 spaces for waist 30.

THE BACKPART.

1 to 13 is $\frac{1}{2}$ and 13 to 14 is $\frac{1}{2}$ inch.

Draw a line through 1 and 14.

2 to 15 is $\frac{1}{2}$ and 15 to 16 is $\frac{1}{2}$ inch.

Draw a line through 2 and 16.

7 to 8 is $2\frac{1}{4}$ inches. Draw a line from 8 through 4.

3 to 17 is $\frac{3}{8}$ inch and 4 to 18 is $\frac{7}{8}$ inch.

Shape line from 17 to 18 and draw a line from A through 5 and 23.

6 to 24 is $\frac{3}{8}$ inch. Line 34 is 5 inches below line 4. 34 to 35 is $\frac{5}{8}$ inch.

9 to 20 and 10 to 19 is on 8ths and 12 to 21 and 11 to 22 is on 16ths.

25 to 26 is $\frac{1}{2}$ inch up and $\frac{1}{4}$ inch back.

Lines 27-28 and 29-30 are parallel with line 25-26.

Divide all these spaces into five parts. Go out 3 parts for waist size 42, and go down four parts for size 30 waist.

For length of leg slide up and down on center line.

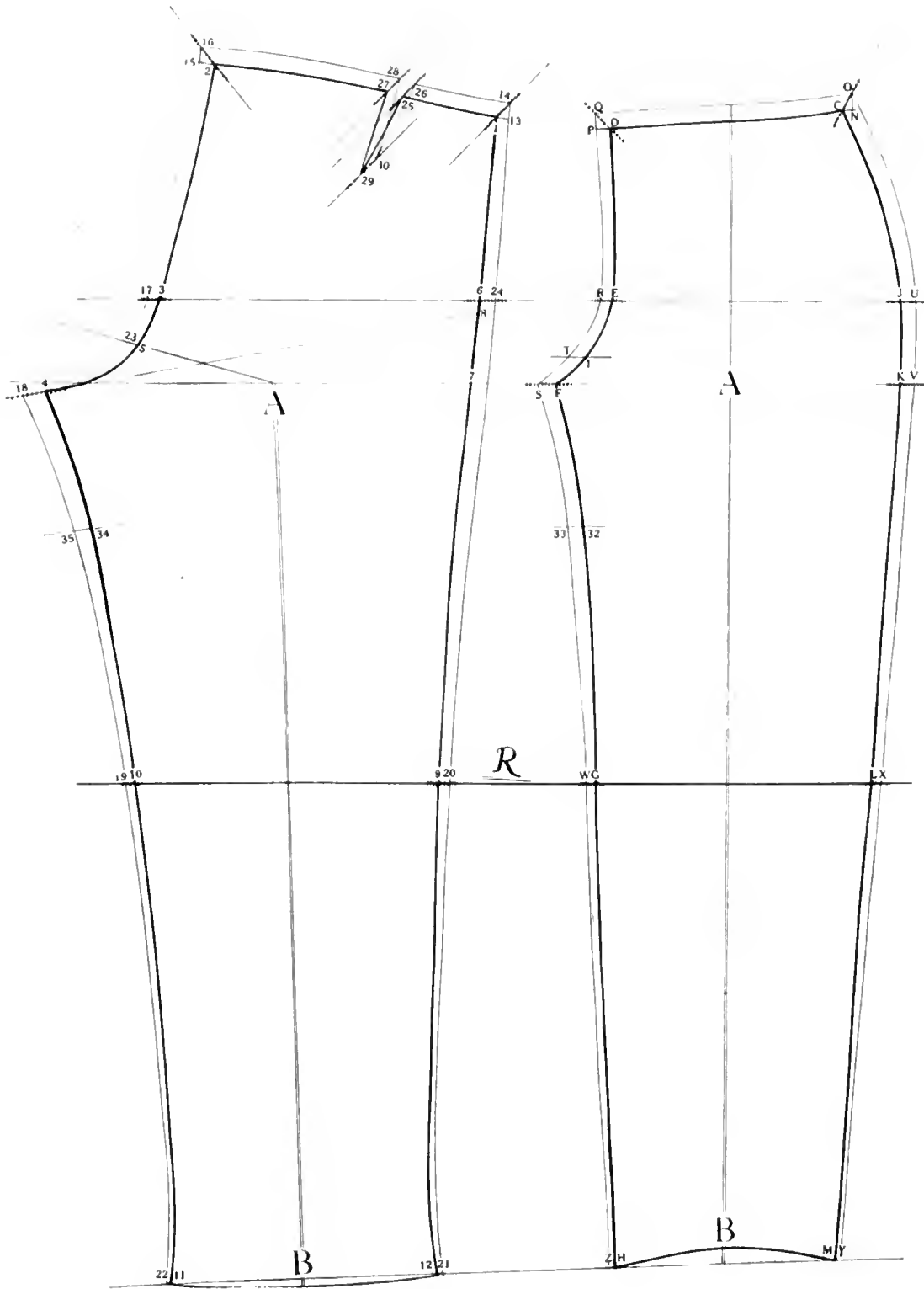

DIAGRAM S

THE FAT MEN'S TROUSERS.

THE FOREPART.

The heavy line shows the 42 waist forepart from which to grade.

A, B is the center line.

C to P is $\frac{1}{2}$ and P to Q $\frac{1}{4}$ inch.

Draw a line through C and Q.

D to N is $\frac{1}{2}$ and N to O is $\frac{1}{2}$ inch.

Draw a line through D and O.

E to Z is $\frac{3}{8}$ and I to R is $\frac{3}{8}$ inch.

J to S is 5-16 inch.

F to Y is $\frac{3}{8}$ and J to S is 5-16 inch.

G to X is $\frac{5}{8}$ inch. Line 36 is 5 inches down from G.

36 to 37 is $\frac{1}{2}$ inch.

K to T and H to W is on 8ths.

L to U and M to V is on 16ths.

Divide all these spaces into 5 parts.

Go out 3 spaces for 50 waist and down 4 spaces for 38 waist.

THE BACKPART.

1 to 12 is $\frac{1}{2}$ and 12 to 13 is $\frac{1}{4}$ inch.

Draw a line through 1 and 13.

2 to 14 is $\frac{1}{2}$ and 14 to 15 is $\frac{1}{4}$ inch.

Draw a line through 2 and 15.

3 to 16 is $\frac{3}{8}$ inch. 25 is $2\frac{1}{2}$ inches above 7. Draw a line from 25 through point 4.

4 to 17 is $\frac{7}{8}$ inch. 38 is 5 inches down from 4. 38 to 39 is $\frac{5}{8}$ inch.

Draw a line from A for 5 and 18.

5 to 18 is $\frac{3}{8}$ inch.

6 to 19 is $\frac{3}{8}$ inch. 7 to 20 is 5-16 inch.

8 to 21 and 9 to 24 is on 8ths.

10 to 23 and 11 to 22 is on 16ths.

Divide all these spaces into 5 parts.

Go out 3 spaces for the 50 waist and come back four spaces for the 38 waist.

For length of leg slide up and down on center line.

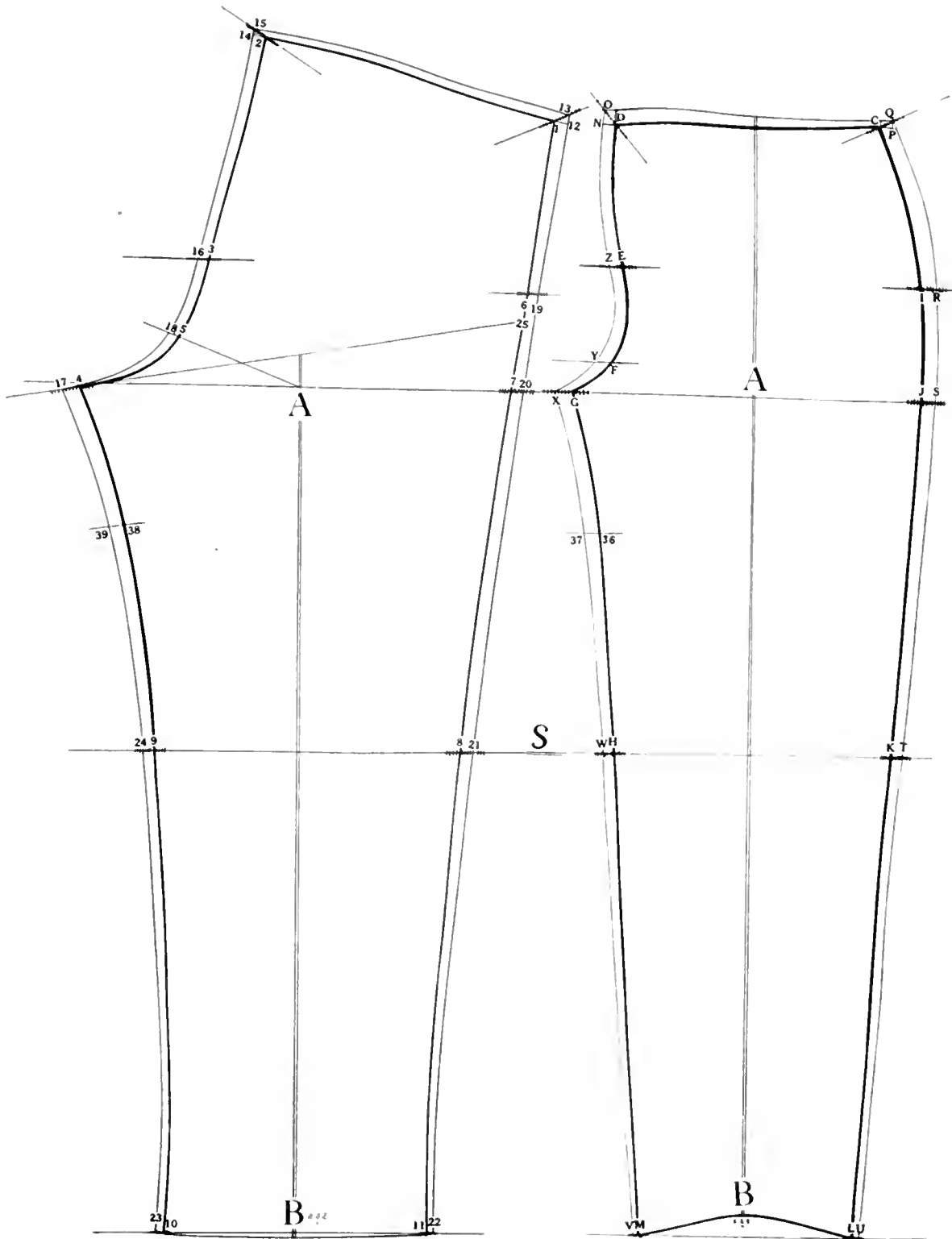

A VALUABLE ASSET

and

Essential Part of an Efficient Equipment

PUBLICATIONS

Stone's Scientific System of Grading.	
<i>In book form</i>	\$10.00
Grading Tools	5.00
Stone's Anatomical Divisions of the Human Form and Form Growth from Birth to Manhood and Womanhood.	
<i>In book form</i>	10.00
Stone's Advanced Coat and Vest System.	
<i>In book form</i>	10.00
Stone's Trouser System.	
<i>In book form</i>	7.00
Stone's System of Cutting Ladies' Garments.	
<i>In book form</i>	10.00
Stone's Shirt and Drawer System.	
<i>In book form</i>	3.00
<hr/>	
The Practical Cutter and Tailor.	
Chuck full of practical methods in cutting, published monthly.	
<i>Per year</i>	\$3.00

Address all orders and send remittances to

THE CHAS. J. STONE CO.

Security Building

CHICAGO, ILL.



TERMS FOR INSTRUCTION
TO BE PAID IN ADVANCE

MEN'S GARMENTS

Preliminary course in drafting by proportions from heights and widths:

Coats alone	\$ 30.00
Vests alone	20.00
Trousers alone	20.00
Coats, Vests and Trousers together.....	50.00

Advanced course in drafting coats and vests by shoulder measure method:

Coats alone	\$ 30.00
Vests alone	20.00
Trousers by actual measure.....	20.00
Coats, Vests and Trousers together.....	50.00

Advanced course in drafting coats, vests and trousers by the short measure method:

Coats alone	\$ 30.00
Vests alone	20.00
Trousers by actual measure.....	20.00
Coats, Vests and Trousers together.....	50.00

Mixed courses: Proportions, shoulder measure and short measure methods combined:

Coats alone	\$ 50.00
Coats and Vests together.....	75.00
Coats, Vests and Trousers.....	100.00
How to Apply Individuality in Cutting.....	25.00
How to Make up Garments.....	\$15 to 25.00
Practical Course: Laying patterns on the cloth, cutting the goods, trimming up of garments and trying on....	50.00

Shirts	25.00
Drawers	15.00
Overalls	15.00
Jumpers	20.00
Canvas Coats	25.00
Hunting Coats	25.00
Military Garments	50.00
Capes, Hoods, Leggings and Gaiters.....	50.00
Riding Breeches	25.00
Shifting Block Patterns, short course.....	25.00
Shifting Block Patterns, full course.....	50.00
Spacing	25.00
Grading	50.00
Anatomical divisions and heights and widths.....	50.00
Form Growth for Sizing Patterns.....	50.00
Copying Garments	25.00
Laying Patterns and Marking on Cloth.....	50.00

Special mixed courses at special prices.

LADIES' GARMENTS

Preliminary Course: Proportionate Method, drafting from heights and widths:

Dress Waists	\$ 15.00
Shirt Waists	15.00
Blouses	15.00
Jackets	15.00
Box Coats	15.00
Capes	10.00
Skirts	15.00
Dress Waists, Blouses, Jackets, Coats, Capes and Skirts together	50.00

Advanced Courses: Drafting by proportion and actual measure methods:

Dress Waists	\$ 25.00
Shirt Waists	25.00
Blouses	25.00
Jackets	25.00
Box Coats	25.00
Capes	15.00
Skirts by actual measure.....	25.00
Dress Waists, Blouses, Jackets, Coats, Capes and Skirts together	50.00

RIDING HABITS

Jackets	\$ 25.00
Side Saddle Riding Skirts.....	25.00
Divided Skirts	15.00
Riding Breeches	25.00
Gaiters and Leggings.....	15.00
Caps	10.00

UNDERWEAR

Night Robes	\$ 25.00
Chemises	25.00
Drawers	20.00
Corset Covers	20.00
Under Skirts	15.00
Drop Skirts	15.00
Spacing	25.00
Grading	50.00
Anatomical divisions of heights and widths.....	50.00
Form Growth for Sizing Patterns.....	50.00
Copying Garments	25.00

Special mixed courses at special prices

FUR GARMENTS

Drafting by proportion from heights and widths:

Jackets and Coats.....	\$ 30.00
Capes and Collarettes.....	25.00
Jackets, Coats, Capes and Collarettes together.....	50.00

PUBLISHERS OF THE PRACTICAL CUTTER AND TAILOR CORRESPONDENCE MUST IN ALL CASES BE ADDRESSED TO THE HOUSE.
ISSUED MONTHLY \$3.00 PER YEAR

STONE'S PRACTICAL INSTRUCTIONS IN DESIGNING CUTTING & GRADING PATTERNS FOR MEN, WOMEN AND CHILDREN

THE CHAS. J. STONE CO.

TAILORS CUTTING SCHOOL

CHAS. J. STONE,
PRINCIPAL & GEN. MGR.

187-191 W. Madison St., cor. 5th Ave.,
Chicago

TELEPHONE MAIN 4972



APR 22 1912

LIBRARY OF CONGRESS



0 014 082 910 9